



LED EMERGENCY INVERTER Installation Instruction

INSTALLATION AND OPERATING INSTRUCTIONS FOR THE FOLLOWING PRODUCTS:

Model: VEMB8W-10V (S)

Product includes the following components:

PARTS	QUANTITY
LED Emergency Driver & Battery	1
Charging Indicator/Testing Button	1
Charging Indicator/Testing Button Wall Cover (Optional)	1
Instruction Sheet	1

Note: Install requires application of the Luminaire Modification Label provided, as per UL. This label includes the statement: "This equipment has more than one power supply connection point." This label must be applied to the fixture housing during installation.

IMPORTANT SAFEGUARDS

When using electrical equipment, basic safety precautions should always be followed including:

READ AND FOLLOW ALL SAFETY INSTRUCTIONS

WARNING: Risk of fire or electric shock. Luminaire wiring and electrical parts may be damaged when drilling for installation of LED Emergency Backup. Check for enclosed wiring and components.

WARNING: Risk of fire or electric shock. This LED Emergency Backup installation requires knowledge of luminaires electrical systems. If not qualified, do not attempt installation. Contact a qualified electrician.

WARNING: Risk of fire or electric shock LED Emergency Backup is only for use in surface mount or recessed Type IC or Non-IC luminaires listed to UL Standards. Suitable for use in damp locations and plenum spaces. Not for use in heated air outlets or hazardous locations.

WARNING: Risk of fire or electric shock. Do not alter, relocate, or remove wiring, lampholders, power supply, or any other electrical component.

WARNING: To prevent wiring damage or abrasion, do not expose wiring to edges of sheet metal or other sharp objects.

WARNING: Do not make or alter any open holes of the wiring enclosure or electrical component enclosure during installation. Only those open holes indicated in the instructions and/or drawings may be added or altered as a result of LED Emergency Backup installation. Do not leave any other open holes in the wiring enclosure or electrical component enclosure during installation.

CAUTION: Before installing, make certain the AC power to the fixture is off.

CAUTION: The electrical rating of this product is 100-347V. Installer must confirm that there is 100- 347V at the fixture before installation.

CAUTION: LEDs are extremely bright. Do not look directly at the LED light source for extended time as over-exposure may cause harm to the eyes.

CAUTION: Verify that all replacement lamp types marked on the installed luminaire are also identified as suitable for use with this emergency battery pack.

The emergency LED driver shall be enclosed by the LED luminaire and bonded to the grounding of LED luminaire (via green grounding wire attached to driver).

Do not use outdoors.

Do not let power supply cords touch hot surfaces.

Do not mount near gas or electric heaters.

Use caution when servicing batteries. Battery acid can cause burns to skin and eyes. If acid is spilled on skin or in eyes, flush acid with fresh water and contact a physician immediately.

Equipment should be mounted in locations and at heights where it will not readily be subjected to tampering by unauthorized personnel.

The use of accessory equipment not recommended by the manufacturer may cause an unsafe condition.

Do not use this equipment for other than intended use.

SAVE THESE INSTRUCTIONS

INSTALLATION

1. Read and understand all warning and notes stated above, before proceeding with installation.

2. Fixture Compatibility & Applications:

The VEMB8 W-10V (S) emergency packs can be used with most LED loads that directly connect Led fixtures AC input . With the constant power while emergency mode. it works with type B led tube light , led downlight .

UL 924 compliant. The emergency pack assembly is accepted as a component of a luminaire where the suitability of the combination shall be determined by UL or Authorities Having Jurisdiction. The as-installed performance of the system must meet or exceed all Federal, State, and Local code requirements.

Specification Chart

Catalog No.	Rated Output Power	Nominal Lumen Output *
VEMB8 W-10V (S)	8 W (Constant)	800Lumens

* Nominal lumen output is based on a standard LED fixture rated efficacy (lumens per watt, lm/w) of 100 lm/w.

Multiply lm/w by Rated Output Power of emergency pack to determine lumen output of fixture during emergency operation.

To calculate actual minimum lumen output of fixture under emergency operation:

- Determine the fixture efficacy under normal AC operation, based on fixture manufacturer published data, in lumens per watt (lm/w).
 - Reference DLC QPL (www.designlights.org) for rated data on fixture efficacy. If fixture is not found on DLC QPL, contact fixture manufacturer.
- Multiply fixture lm/w by rated output power of emergency pack. (Example: 100 lm/w x 8 W = 800 lumens.)

3. Determining Adequacy of Means-of-Egress Lighting Levels

Follow industry standards by utilizing available .ies files and lighting design software for your dedicated emergency luminaires , with the above calculated emergency lumens, and validate your as-installed plans in accordance with the applicable life safety codes governing your project.

While these products are compliant with the requirements of UL Standard 924, it is ultimately the responsibility of the designer/specifier to assure the as-installed system delivers code compliant path of egress illumination in accordance with federal, state or local municipal requirements.

Complete wiring as indicated below. Install in accordance with National Electric Code. Emergency Pack and AC Driver must be on the same branch circuit. Ensure hot / live lead going to the black wire on the Emergency LED driver is Un-Switched. When used with switched fixtures, the emergency pack must be wired ahead of the switch. Charging indicator/testing button wall cover is optional to use when wall mounting indicator is needed.

Wiring Diagram:

1. Emergency Solution with 0-10V LED driver and using 0-10V dimmer (* LED DRIVER INPUT POWER NOT GREATER THAN 50W)

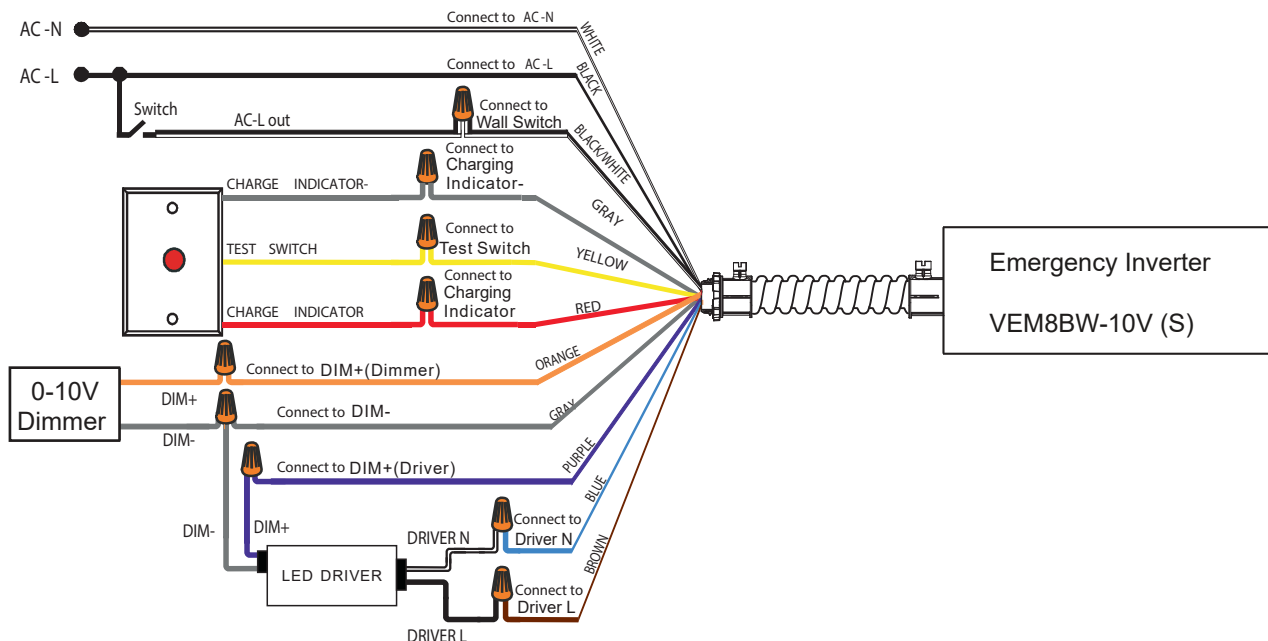

2. Emergency Solution with 0-10V LED driver, without using 0-10V dimmer (* LED DRIVER INPUT POWER NOT GREATER THAN 50W)

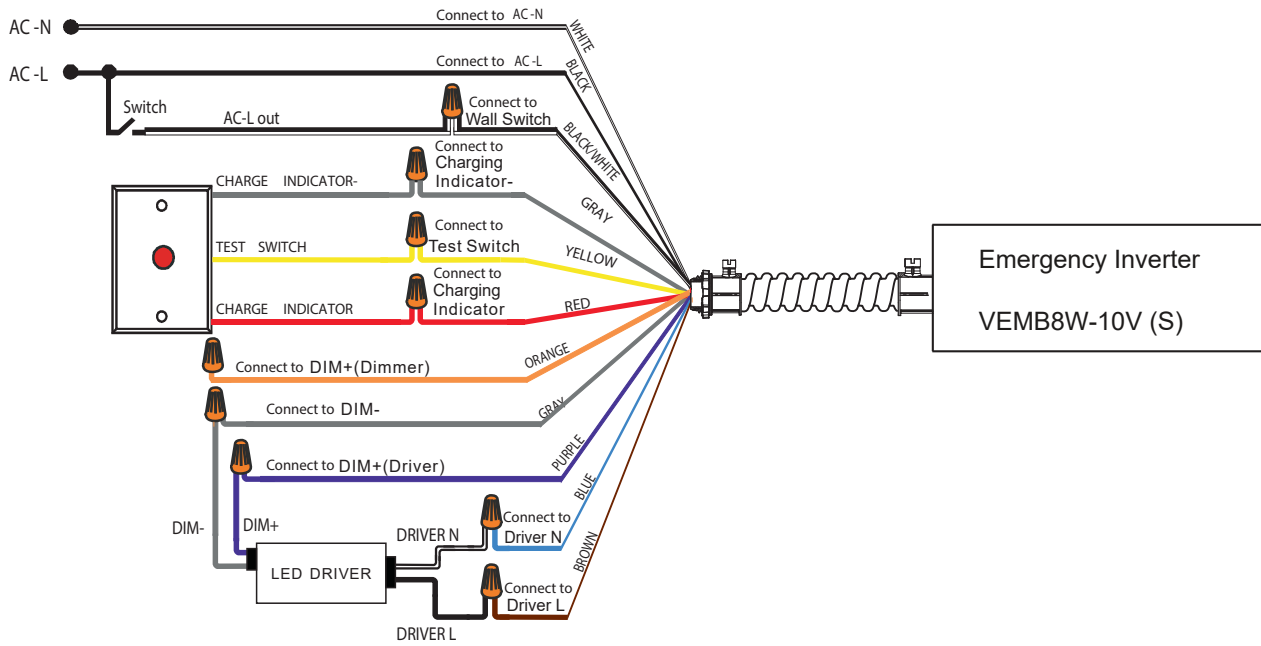

3. Emergency Solution with non-dimming LED driver (* LED DRIVER INPUT POWER NOT GREATER THAN 8W)

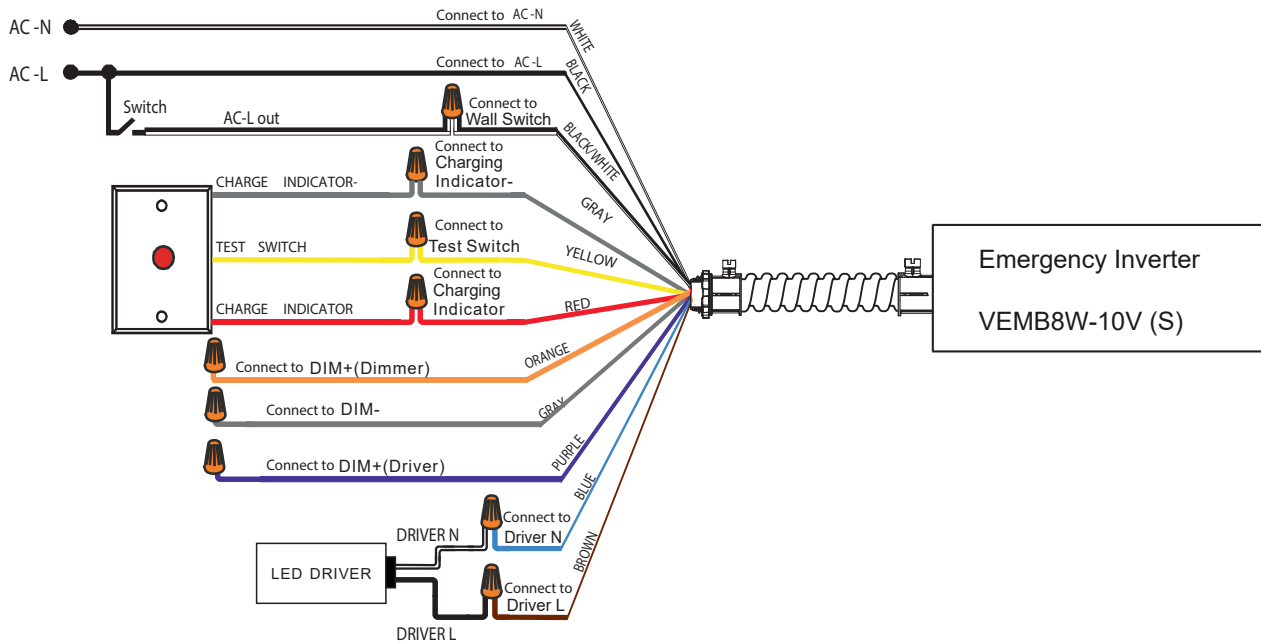

4. Complete Installation:

When the installation is complete, verify all necessary connections have been made. Switch the AC Power on and join the battery pack connector.

5. Operation:

Normal Mode: AC power is present. The AC driver operates the LED load as designed. The emergency pack is charging in a standby mode. The test button will be light not flicking , showing that the battery is charging.

Emergency Mode: When the AC power goes out, the emergency pack detects the power outage and automatically switches to the emergency mode. The LED load is illuminated, for a minimum of 90 minutes. When AC power is restored, the emergency pack switches back to Normal Mode and starts re-charging.

6. Self-Diagnostic

The integrated self-diagnostic circuitry will automatically conduct monthly 30-second and annual 90-minute tests to verify proper emergency capability per Life Safety Code requirements.

Press the test button to the emergency mode with 30seconds, after 30seconds the fixtures turn into the AC mode automatically, when the emergency mode, press the test button turn off the emergency mode, then can disconnect the wire between emergency driver and fixtures .

NFPA 101, Life Safety Code outlines the following schedule:

Monthly - Insure that the test button light is illuminated. Conduct a 30 second discharge test by depressing the test button. The LED load should operate at reduced output.

Annually - Insure that the test button is illuminated. Conduct a full 90 minute discharge test. The unit should operate as intended for the duration of the test.

“Written records of the testing shall be kept by the owner for inspection by the authority having jurisdiction.”